

ECT-HM series 60Hz Submersible Portable Dewatering Pumps



ECT PUMP



Pump Data

1. Impeller : Vortex Impeller
2. Shaft Seal / Mechanical : Double Mechanical Seal
3. Bearing : Double-shielded Ball Bearing

Operating Conditions

1. Fluid Temperature : 0 to 40°C(104°F)

Motor Data

1. Motor Type : 2 pole, dry type
2. Frequency : 60Hz
3. Nominal Speed : 3450 rpm
4. Insulation Class : F class (155°C)
5. Enclosure Protection Class : IP68
6. Protection Device :
Thermal Protector (Single phase)
Overload Protector (Three phase)

APPLICATIONS

1. Basement water removal
2. Waste water drainage
3. Water transfer
4. Sump / effluent handling
5. Dewatering
6. Fish pond & fountain circulation
7. Factory waste water handling

MATERIAL CONSTRUCTION

No.	Part	Materials
1	Cable	STOW_UL
2	Handle	Nylon6-30GF
3	Motor Cover	FC200
4	Bearing cap	FC200
5	Motor frame	AISI 304
6	Bearing Bracket	FC200
7	M.Seal Bracket	FC200
8	Cable Base	Nylon6+30GF
9	Motor Shaft	AISI410
10	Mechanical seal	CA / CE , SIC / SIC
11	Oil Seal	NBR70
12	Impeller	TPU
13	Pump casing	FC200
14	Flange	FC200
15	Strainer	PVC

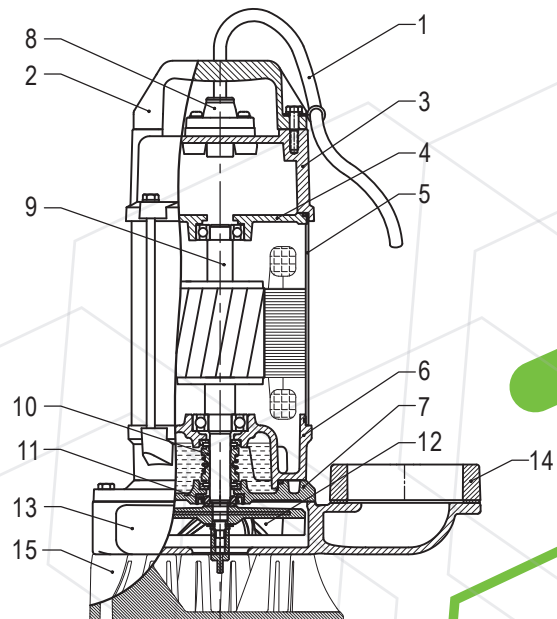



ECT PUMP

ECT-HM series Submersible Portable Dewatering Pumps

PERFORMANCE CURVE

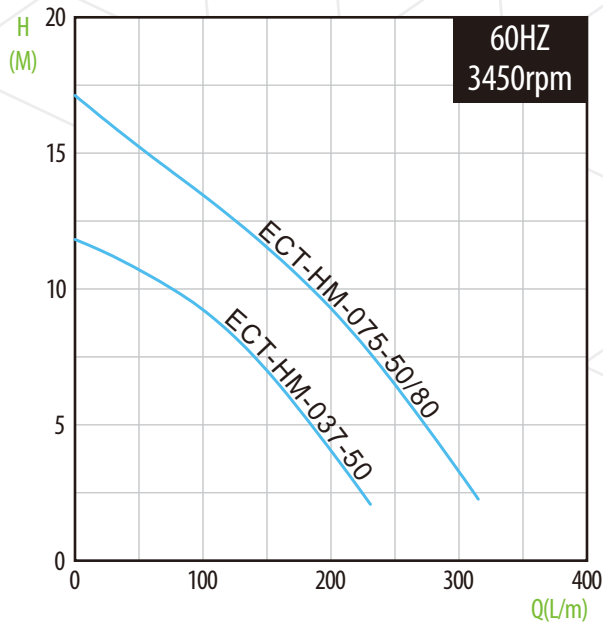

SPECIFICATION

A : Auto Float Switch

Model	Power HP(kW)	Discharge Inch(mm)	Nominal Current [A]		Capacitort		Std. Head M	Std. Flow LPM	Max. Head M	Max. Flow LPM	Weight KG
			110 - 127V	220 - 230V	110 - 127V UF / V	220 - 230V UF / V					
Single Phase & Auto Float Switch											
ECT-HM(A)-1037-50	0.5 (0.37)	2" (50)	5.6 - 4.9	2.6 - 2.5	50 / 250	12 / 450	7	140	11.9	230	12.9 / 13.4
ECT-HM(A)-1075-50/80	1 (0.75)	2"/3" (50/80)	10.8 - 9.4	5.4 - 5.2	80 / 250	20 / 450	10	190	17.2	316	15.1 / 15.6

Model	Power HP(kW)	Discharge Inch(mm)	Nominal Current [A]			Std. Head M	Std. Flow LPM	Max. Head M	Max. Flow LPM	Weight KG
			220 - 230V	380 - 440V	460 - 480V					
Three Phase										
ECT-HM-3037-50	0.5 (0.37)	2" (50)	2.1 - 2.0	1.2 - 1.1	1.2 - 1.0	7	140	11.9	230	11.9
ECT-HM-3075-50/80	1 (0.75)	2"/3" (50/80)	3.3 - 3.2	1.9 - 1.8	1.8 - 1.6	10	190	17.2	316	14.1

DIMENSIONS

Model	Discharge(mm)							Solid Passage (mm)	Cable	
	A	A1	H	H1	H2	H3	H4		Cable	M
ECT-HM(A)-1037-50	254	120	365	264	110	115	535	10	16AWGx3C	10
ECT-HM-3037-50	254	120	365	264	110	-	-	10	16AWGx4C	10
ECT-HM-1075-50/80	285	135	380	279	116	130	550	10	16AWGx3C	10
ECT-HM(A)-3075-50/80	285	135	380	279	116	-	-	10	16AWGx4C	10

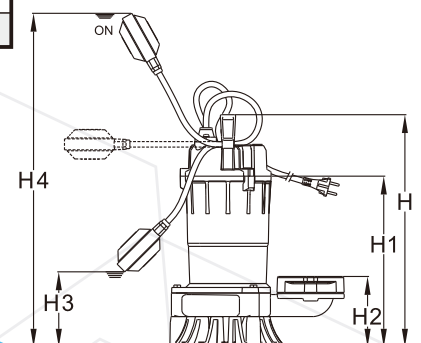
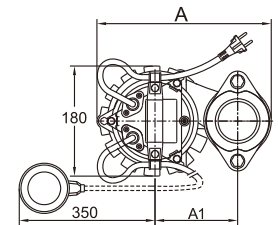

ECT-HM series Guide Rail series



ECT PUMP

TS-50



Pump Model	DN (mm)	Dimensions H1 (mm)
ECT-HM Series For 0.5 HP	50	48

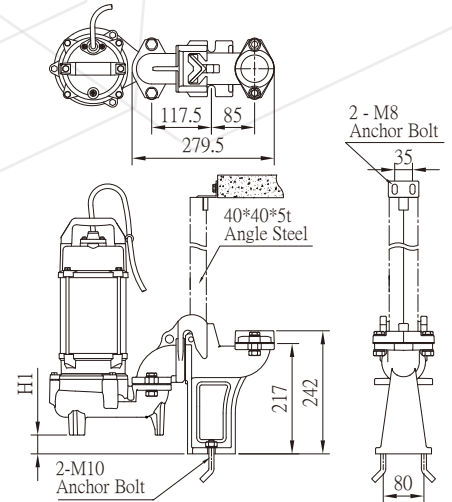

TSL-50/80

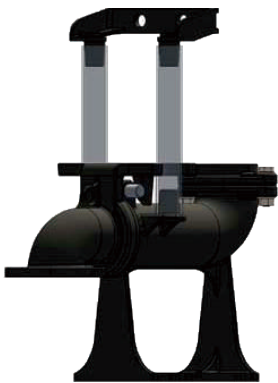

Pump Model	DN (mm)	Dimensions H1 (mm)
ECT-HM Series For 1 HP	50 & 80	43

