

ECT-4CF / ECT-6CF series



ECT PUMP

Encapsulated-resin Filled Motors

50 / 60Hz



Standard Voltage					
4"	50Hz	1Ø	0.5-5HP	0.37-3.7kW	220-240V
		3Ø	0.5-7.5HP	0.37-5.5kW	220-240V 380-415V
	60Hz	1Ø	0.5HP	0.37kW	110-115V
			0.5-5HP	0.37-3.7kW	220-230V
60Hz	3Ø	0.5-7.5HP	0.37-5.5kW	220-230V	
				380-400V	
460V					

Standard Voltage					
6"	50Hz	3Ø	5.5-30HP	4.0-22kW	220-240V
			5.5-50HP	4.0-37kW	380-415V
	60Hz	3Ø	5.0-30HP	3.7-22kW	220-230V
			5.0-50HP	3.7-37kW	380V
		5.0-50HP	3.7-37kW	460V	

Encapsulated-resin filled motor is developed with market expectation to meet the robust construction and stringent requirement, which is for 4" & 6" or larger well. The motor is 100% tested before shipment.

4" FEATURES

1. Hermetically sealed stator, anti-track, stator resin filled prevent motor burn out.
2. High efficiency provides operation cost savings.
3. Thrust pad.
4. Copper wiring.
5. Pressure equalizing diaphragm.
6. Removable lead connector.
7. Control boxes available for single phase motor.
8. Standard NEMA mounting dimensions.
9. Lightning arrester is available in option (Single phase).

4" TECHNICAL SPECIFICATION

1. Upper bracket: Cataphoresis treated cast iron plus SS304 cover cap.
2. Max. Immersion depth: 200m
3. Protection: IP68
4. Nos. of start per hour: max 20 at regular intervals.
5. Sand slinger and lip seal.
6. Insulation: Class F
7. Rated ambient temperature: 30°C with min.
8. Cooling flow 0.08 m/s of water flow speed
9. Standard installation position: vertical and horizontal

6" FEATURES

1. Hermetically sealed stator, anti-track, stator resin filled prevent motor burn out.
2. High efficiency provides operation cost savings.
3. Thrust pad.
4. Copper wiring.
5. Pressure equalizing diaphragm.
6. Removable lead connector.
7. Standard NEMA mounting dimensions.
8. Motor with carbon and ceramic Mechanical seal.(Optional : SiC / SiC)

6" TECHNICAL SPECIFICATION

1. Max. Immersion depth: 350m
2. Protection: IP68
3. Nos. of start per hour: max 20 at regular intervals
4. Insulation: Class F
5. Max temp. 30° with water cooling flow min. 0.16 m/s
6. Standard installation position: vertical and horizontal
7. Starting method: D.O.L / Star-Delta



ECT PUMP

ECT-4CF / ECT-6CF Dimensions

Cast iron / 304SS / 316SS

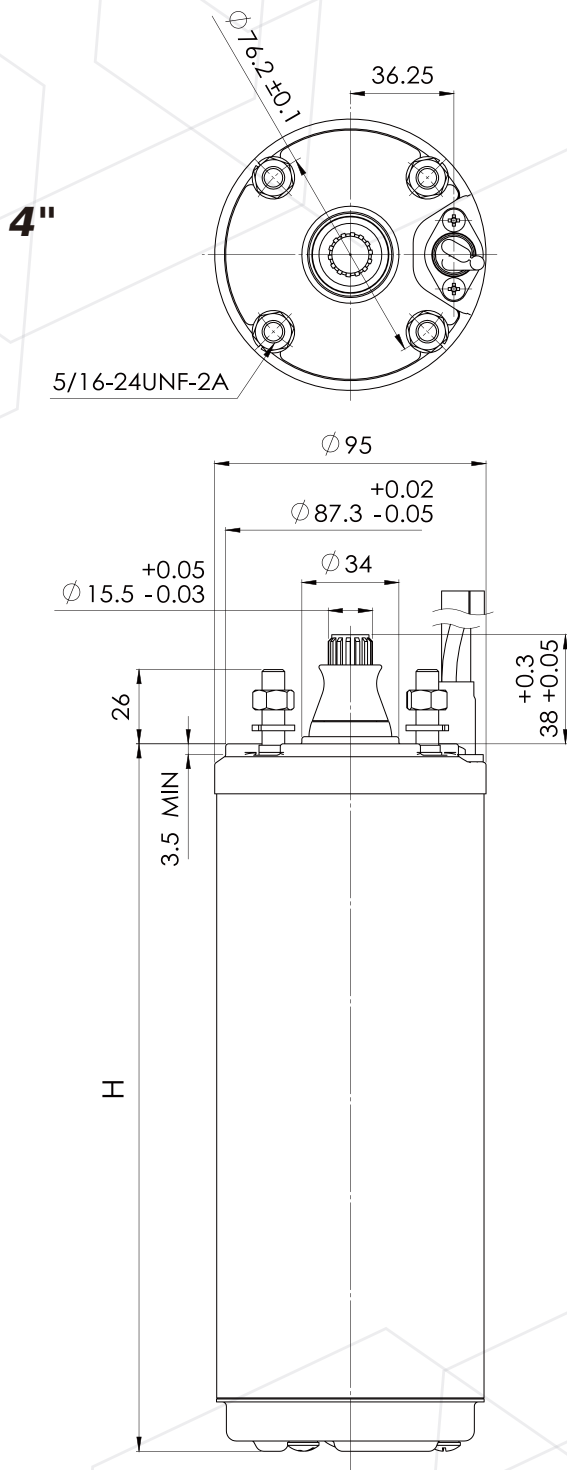

Single Phase 2 Wire

HP	kW	H(mm)
0.5	0.37	294
0.75	0.55	321
1	0.75	364
1.5	1.1	409

Single Phase 3 Wire

HP	kW	H(mm)
0.5	0.37	248
0.75	0.55	275
1	0.75	298
1.5	1.1	347
2	1.5	388
3	2.2	473
5	3.7	704

Three Phase

HP	kW	H(mm)
0.5	0.37	248
0.75	0.55	275
1	0.75	298
1.5	1.1	298
2	1.5	352
3	2.2	396
4	3	551
5	3.7	551
5.5	4	614
7.5	5.5	704



ECT PUMP

ECT-4CF / ECT-6CF

Dimensions

6"

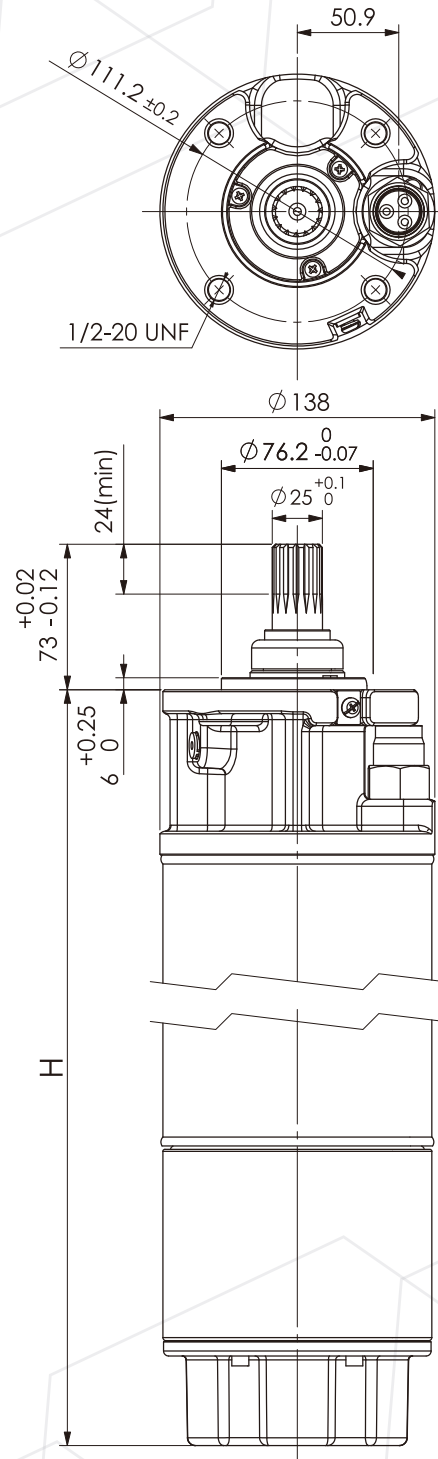
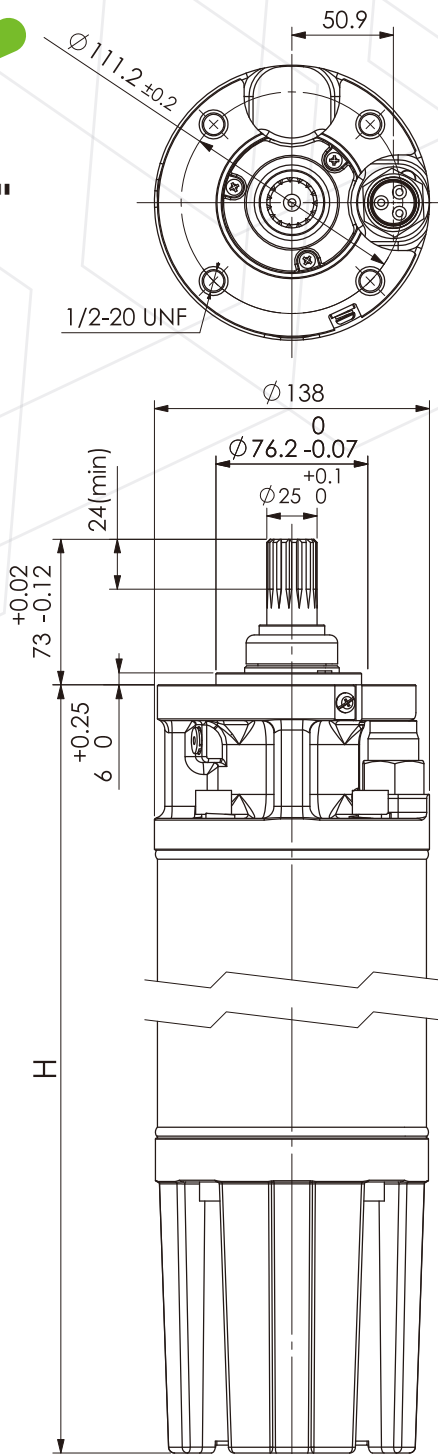

Cast iron

HP	kW	H(mm)
5	3.7	582
5.5	4	582
7.5	5.5	627
10	7.5	662
15	11	727
20	15	787
25	18.5	857
30	22	907
40	30	1047
50	37	1417

304SS / 316SS

HP	kW	H(mm)
5	3.7	574
5.5	4	574
7.5	5.5	619
10	7.5	654
15	11	719
20	15	779
25	18.5	849
30	22	899
40	30	1039
50	37	1409

ECT-4CF / ECT-6CF Component



ECT PUMP

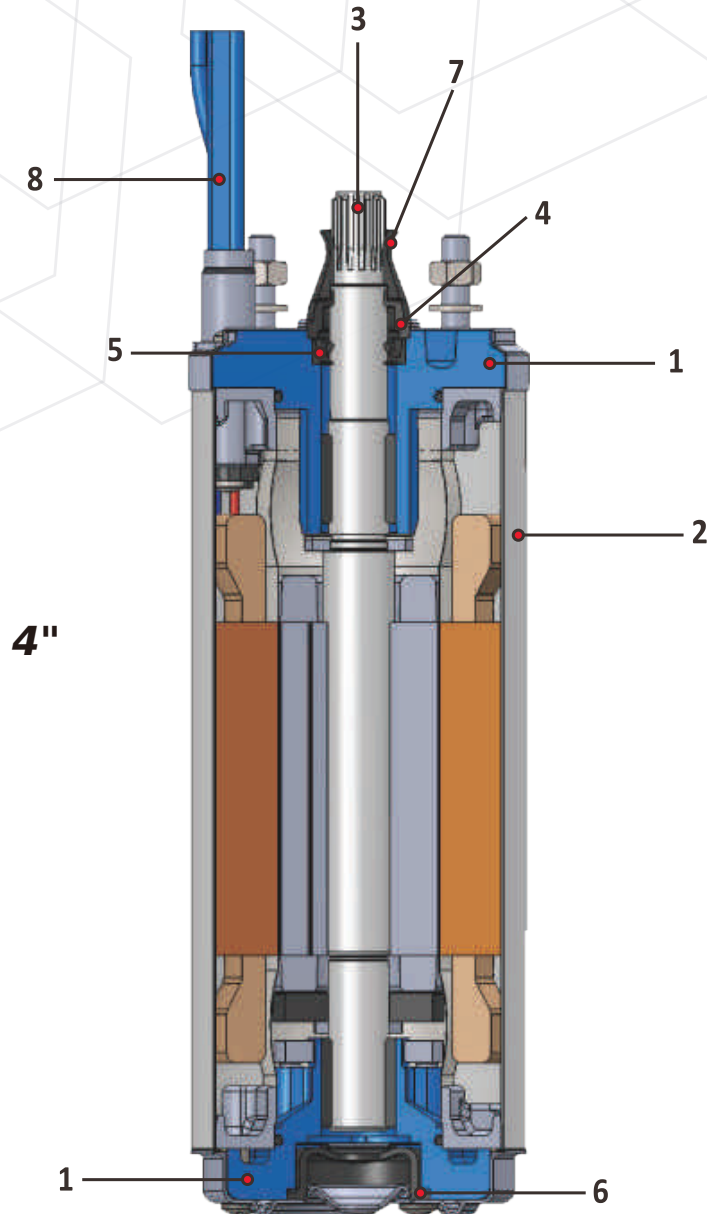

Example

NO.	Component	4CF	4CS	4CN
1	Upper/Lower Bracket	AISI 304 Over Iron	AISI 304	AISI 316
2	Stator Shell	AISI 304	AISI 304	AISI 316
3	Shaft	AISI 420	AISI 420	AISI 630
4	Seal Cover	Nylon	Nylon	Nylon
5	Lip Seal	NBR	NBR	NBR
6	Diaphragm	NBR	NBR	NBR
7	Sand Slinger	NBR	NBR	NBR
8	Lead Wire (Cable)	XLPE	XLPE	XLPE
	Bolts and Screws	AISI 304	AISI 304	AISI 316
	Lead Potting	Epoxy	Epoxy	Epoxy
	Thrust Pad	AISI 420	AISI 420	AISI 420

ECT-4CF / ECT-6CF Component



ECT PUMP

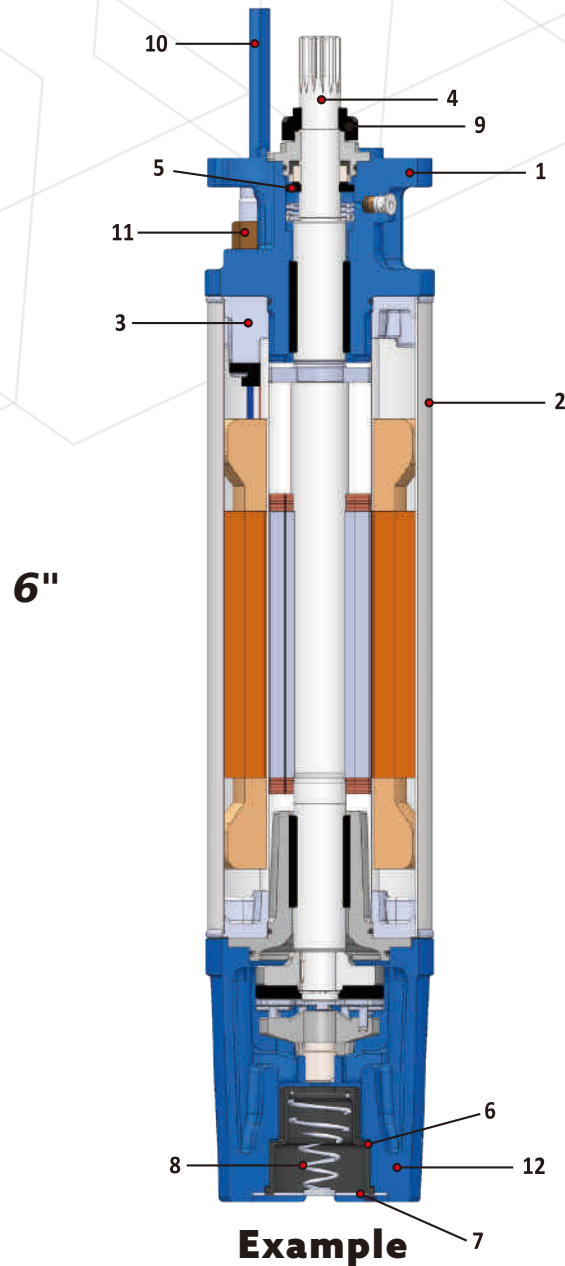

NO.	Component	6CF	6CS	6CN
1	Upper Bracket	Cast iron	AISI 304	AISI 316
2	Stator Shell	AISI 304	AISI 304	AISI 316
3	Stator Ends	Carbon steel	AISI 304	AISI 316
4	Shaft	AISI 420	AISI 420	AISI 630
5	Mechanical Seal	Carbon / ceramic	Carbon / ceramic	SiC / SiC
6	Diaphragm	NBR	NBR	NBR
7	End Cover	AISI 304	AISI 304	AISI 316
8	Spring	AISI 304	AISI 304	AISI 316
9	Sand Slinger	NBR	NBR	NBR
10	Lead Wire (Cable)	XLPE	XLPE	XLPE
11	Cable Jam Nut	Brass	AISI 304	AISI 316
12	Lower Bracket	Cast iron	AISI 304 over Iron	AISI 316 over Iron
	Lead Potting	Epoxy	Epoxy	Epoxy
	Mechanical Seal / Rubber Components	NBR	NBR	NBR
	Thrust Pad	AISI 420	AISI 420	AISI 420



Technical Data

Single Phase 2 Wire 50HZ 220-240V

Motor	P2		Voltage V	In A	Istart A	PF% COSφ	Efficiency %	Nn RPM	Thrust N	CAPACITOR UF	Cable		N.W kg	G.W kg
	HP	KW									M	mm ²		
ECT-4CF2005M	0.5	0.37	220	3.2	13.9	0.92	57.2	2850	2000N	16UF 450V	1.7	1.5	10.44	10.83
			230	3.3	14.7	0.88								
			240	3.4	15.4	0.84								
ECT-4CF2015M	0.75	0.55	220	5.0	20.0	0.85	57.7	2850	2000N	20UF 450V	1.7	1.5	10.80	11.19
			230	5.3	21.0	0.78								
			240	5.9	21.8	0.73								
ECT-4CF3025M	1	0.75	220	6.7	23.2	0.84	60.5	2850	3000N	25UF 450V	1.7	1.5	11.81	12.36
			230	6.5	24.2	0.83								
			240	6.3	25.2	0.83								
ECT-4CF3035M	1.5	1.1	220	7.6	31.5	0.93	70.0	2850	3000N	35UF 450V	1.7	1.5	13.09	13.48
			230	7.9	32.1	0.89								
			240	8.5	33.3	0.85								

* Lightning arrester is available in option.

Single Phase 3 Wire 50HZ 220-240V

Motor	P2		Voltage V	In A	Istart A	PF% COSφ	Efficiency %	Nn RPM	Thrust N	Cable		N.W kg	G.W kg
	HP	KW								M	mm ²		
ECT-4CF2005R	0.5	0.37	220	3.2	13.9	0.92	57.2	2850	2000N	1.7	1.5	9.34	9.73
			230	3.3	14.7	0.88							
			240	3.4	15.4	0.84							
ECT-4CF2015R	0.75	0.55	220	5.0	20.0	0.85	57.7	2850	2000N	1.7	1.5	10.50	10.89
			230	5.3	21.0	0.78							
			240	5.9	21.8	0.73							
ECT-4CF3025R	1.0	0.75	220	6.7	23.2	0.84	60.5	2850	3000N	1.7	1.5	10.92	11.31
			230	6.5	24.2	0.83							
			240	6.3	25.2	0.83							
ECT-4CF3035R	1.5	1.1	220	7.6	31.5	0.93	70.0	2850	3000N	1.7	1.5	12.10	12.86
			230	7.9	32.1	0.89							
			240	8.5	33.3	0.85							

* To be used with Run Capacitor type control box.

* Lightning arrester is available in option.

Single Phase 3 Wire 50HZ 220-240V

Motor	P2		Voltage V	In A	Istart A	PF% COSφ	Efficiency %	Nn RPM	Thrust N	Cable		N.W kg	G.W kg
	HP	KW								M	mm ²		
4CF3035D	1.5	1.1	220	9.7	32.8	0.84	61.0	2850	3000N	1.7	1.5	13.07	13.46
			230	9.9	34.6	0.79							
			240	10.0	36.4	0.76							
4CF3045D	2.0	1.5	220	10.9	41.0	0.88	70.5	2850	3000N	1.7	1.5	14.77	15.32
			230	10.8	43.2	0.85							
			240	10.9	45.5	0.82							
4CF4055D	3.0	2.2	220	15.4	60.1	0.94	68.7	2850	4000N	2.5	1.5	18.16	18.92
			230	15.2	63.2	0.92							
			240	15.0	66.4	0.89							
4CF6075D	5.0	3.7	220	23.9	104.5	0.96	72.8	2850	6000N	2.5	2.0	29.13	30.11
			230	22.9	110.7	0.95							
			240	22.7	116.9	0.93							

* To be used with Double Capacitor (Run & Start) type control box.

* Lightning arrester is available in option.

ECT-4CF



ECT PUMP

Control Box

Single Phase 50HZ

EU standard

MODEL	TYPE	HZ	POWER	VOLTAGE	REMARK	START CAPACITOR MFD	RUN CAPACITOR UF	RELAY
ECT-SBC00R	RUN CAPACITOR (SMALL BOX)	50	0.5HP	220~240V	RUN CAPACITOR * 1 OVERLOAD PROTECTOR*1	-	16UF 450V	-
ECT-SBC01R			0.75HP			-	20UF 450V	
ECT-SBC02R			1.0HP			-	25UF 450V	
ECT-SBC03R			1.5HP			-	35UF 450V	
ECT-BBC03D	DOUBLE CAPACITOR (BIG BOX)	50	1.5HP	220~240V	START CAPACITOR * 1 RUN CAPACITOR * 1 RELAY * 1 OVERLOAD PROTECTOR (1.5 HP * 1、 2 - 5 HP * 2)	105-126MFD 250V	10UF 400V	P.U:180~195 VAC D.O: 40~105 VAC FLA:16A 277V RES:35A 277V
ECT-BBC04D			2.0HP			189-227MFD 250V	20UF 400V	
ECT-BBC05D			3.0HP			270-324MFD 250V	35UF 400V	
ECT-BBC07D			5.0HP			378-454MFD 250V	75UF 400V	

Dimension

Type	Model	Carton box size			Bottom knockouts		Side knockouts	
		L	W	H	Quantity	Diameter	Quantity	Diameter
ECT-PSC (ECT-CR)	ECT-SBC00R	25cm (9.9")	14cm (5.5")	9cm (3.6")	2	Ø21.9mm (Ø0.86")	2	Ø21.9mm (Ø0.86")
	ECT-SBC01R							
	ECT-SBC02R							
	ECT-SBC03R							
ECT-CSCR (ECT-CSR)	ECT-BBC03D	29cm (11.5")	21.5cm (8.5")	16.5cm (6.5")	2	Ø33mm (Ø1.3")	-	-
	ECT-BBC04D							
	ECT-BBC05D							
	ECT-BBC07D							

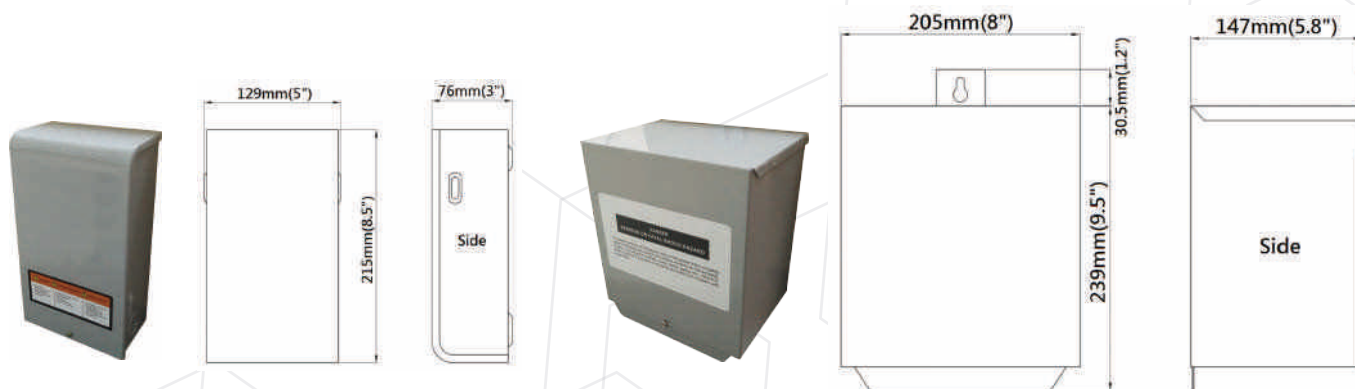



Technical Data

Three Phase 50HZ 220-240V

Motor	P2		Voltage	In	Istart	PF%	Efficiency	Nn	Thrust	Cable		N.W	G.W
	HP	KW	V	A	A	COSφ	%	RPM	N	M	mm ²	kg	kg
ECT-4CF2205	0.5	0.37	220	1.7	8.2	0.78	69.3	2850	2000N	1.7	1.5	7.52	7.91
			230	1.7	8.8	0.75							
			240	1.7	9.4	0.72							
ECT-4CF2215	0.75	0.55	220	2.8	14.8	0.74	71.7	2850	2000N	1.7	1.5	9.13	9.52
			230	2.8	16.0	0.68							
			240	2.8	16.8	0.65							
ECT-4CF3225	1.0	0.75	220	3.4	19.2	0.75	74.1	2850	3000N	1.7	1.5	10.23	10.62
			230	3.6	20.4	0.71							
			240	3.6	21.4	0.67							
ECT-4CF3235	1.5	1.1	220	5.0	24.8	0.79	71.8	2850	3000N	1.7	1.5	10.31	10.70
			230	5.1	26.0	0.75							
			240	5.3	27.2	0.70							
ECT-4CF3245	2.0	1.5	220	6.9	21.0	0.76	75.4	2850	3000N	1.7	1.5	14.08	14.47
			230	7.1	43.0	0.70							
			240	7.5	44.8	0.65							
ECT-4CF4255	3.0	2.2	220	9.5	43.1	0.81	74.3	2850	4000N	2.5	1.5	14.78	15.33
			230	9.6	45.2	0.77							
			240	10.0	47.4	0.72							
ECT-4CF6265	4.0	3.0	220	11.8	81.5	0.82	75.0	2850	6000N	2.5	1.5	17.69	18.50
			230	12.1	85.7	0.77							
			240	12.7	89.9	0.71							
ECT-4CF6275	5.5	4.0	220	17.8	106.3	0.78	75.2	2850	6000N	2.5	1.5	25.06	25.90
			230	18.5	111.8	0.72							
			240	18.7	117.1	0.68							
ECT-4CF6285	7.5	5.5	220	22.3	116.7	0.86	76.6	2850	6000N	2.5	2.0	28.45	29.43
			230	22.6	122.9	0.81							
			240	23.1	128.8	0.77							

Three Phase 50HZ 380-415V

Motor	P2		Voltage	In	Istart	PF%	Efficiency	Nn	Thrust	Cable		N.W	G.W
	HP	KW	V	A	A	COSφ	%	RPM	N	M	mm ²	kg	kg
ECT-4CF2105	0.5	0.37	380	1.0	4.1	0.78	69.3	2850	2000N	1.7	1.5	8.57	8.96
			400	1.0	4.4	0.75							
			415	1.0	4.7	0.72							
ECT-4CF2115	0.75	0.55	380	1.6	7.4	0.74	71.7	2850	2000N	1.7	1.5	9.83	10.22
			400	1.6	8.0	0.68							
			415	1.6	8.4	0.65							
ECT-4CF3125	1.0	0.75	380	2.0	9.6	0.75	74.1	2850	3000N	1.7	1.5	10.98	11.37
			400	2.1	10.2	0.71							
			415	2.1	10.7	0.67							
ECT-4CF3135	1.5	1.1	380	2.9	14.3	0.82	68.9	2850	3000N	1.7	1.5	10.91	11.30
			400	2.9	15.1	0.78							
			415	3.0	15.7	0.74							
ECT-4CF3145	2.0	1.5	380	4.0	20.5	0.76	75.4	2850	3000N	1.7	1.5	13.27	13.66
			400	4.1	21.5	0.70							
			415	4.3	22.4	0.65							
ECT-4CF4155	3.0	2.2	380	5.5	24.5	0.85	72.0	2850	4000N	2.5	1.5	14.87	15.42
			400	5.8	26.1	0.76							
			415	6.0	27.4	0.71							
ECT-4CF6165	4.0	3.0	380	7.4	47.0	0.82	75.0	2850	6000N	2.5	1.5	21.96	22.77
			400	7.5	49.5	0.77							
			415	7.6	51.9	0.73							
ECT-4CF6175	5.5	4.0	380	10.4	61.4	0.78	75.2	2850	6000N	2.5	1.5	24.92	25.76
			400	10.7	64.5	0.72							
			415	10.8	67.6	0.68							
ECT-4CF6185	7.5	5.5	380	13.0	67.4	0.86	74.6	2850	6000N	2.5	2.0	29.07	30.05
			400	13.0	70.9	0.81							
			415	13.3	74.4	0.77							



Technical Data

Single Phase 2 Wire 60HZ 110-115V

Motor	P2		S.F	Voltage	In	Imax	Istart	PF%		Efficiency%		Nn	Thrust	CAPACITOR	Cable		N.W	G.W
	HP	KW		V	A	A	A	allowable Load	overload Factor	allowable Load	overload Factor	RPM	N	UF	M	AWG	kg	kg
ECT-4CF2606M	0.5	0.37	1.6	110	6.8	9.3	26.0	0.96	0.98	50.8	58.8	3450	2000N	45UF 250V	1.2	14	9.34	9.73
				115	7.1	9.3	26.9	0.94	0.97									

Single Phase 2 Wire 60HZ 220-230V

Motor	P2		S.F	Voltage	In	Imax	Istart	PF%		Efficiency%		Nn	Thrust	CAPACITOR	Cable		N.W	G.W
	HP	KW		V	A	A	A	allowable Load	overload Factor	allowable Load	overload Factor	RPM	N	UF	M	AWG	kg	kg
ECT-4CF2506M	0.5	0.37	1.6	220	3.3	4.4	15.2	0.95	0.97	52.8	62.1	3450	2000N	16UF 450V	1.2	14	9.25	9.64
				230	3.3	4.5	15.8	0.93	0.96									
ECT-4CF2516M	0.75	0.55	1.5	220	6.1	7.0	21.9	0.82	0.88	49.0	60.3	3450	2000N	20UF 450V	1.2	14	10.41	10.8
				230	6.6	6.7	23.0	0.75	0.83									
ECT-4CF3526M	1.0	0.75	1.4	220	5.5	7.0	23.5	0.98	0.99	62.7	68.2	3450	3000N	25UF 450V	1.2	14	11.53	12.08
				230	5.4	6.8	24.2	0.97	0.98									
ECT-4CF3536M	1.5	1.1	1.3	220	8.0	10.3	31.0	0.97	0.97	64.3	64.8	3450	3000N	30UF 450V	1.2	14	13.49	14.25
				230	7.7	9.4	31.8	0.95	0.96									

* Lightning arrester is available in option.

Single Phase 3 Wire 60HZ 110-115V

Motor	P2		S.F	Voltage	In	Imax	Istart	PF%		Efficiency%		Nn	Thrust	Cable		N.W	G.W
	HP	KW		V	A	A	A	allowable Load	overload Factor	allowable Load	overload Factor	RPM	N	M	AWG	kg	kg
ECT-4CF2606S	0.5	0.37	1.6	110	9.6	12.9	38.7	0.68	0.81	50.9	51.2	3450	2000N	1.2	14	8.64	9.03
				115	9.9	12.3	41.1	0.66	0.78								

* To be used with Start Capacitor type control box.

* Lightning arrester is available in option.

Single Phase 3 Wire 60HZ 220-230V

Motor	P2		S.F	Voltage	In	Imax	Istart	PF%		Efficiency%		Nn	Thrust	Cable		N.W	G.W
	HP	KW		V	A	A	A	allowable Load	overload Factor	allowable Load	overload Factor	RPM	N	M	AWG	kg	kg
ECT-4CF2506S	0.5	0.37	1.6	220	5.0	5.8	22.0	0.57	0.53	49.2	53.2	3450	2000N	1.2	14	8.65	9.04
				230	5.4	6.5	23.1	0.60	0.74								
ECT-4CF2516S	0.75	0.55	1.5	220	7.0	7.8	31.6	0.59	0.72	51.1	56.4	3450	2000N	1.2	14	9.9	10.29
				230	7.8	8.8	33.3	0.60	0.72								
ECT-4CF3526S	1.0	0.75	1.4	220	8.1	10.0	36.4	0.70	0.78	60.1	60.6	3450	3000N	1.2	14	10.87	11.26
				230	8.3	9.8	38.1	0.65	0.75								

* To be used with Start Capacitor type control box.

* Lightning arrester is available in option.

Single Phase 3 Wire 60HZ 220-230V

Motor	P2		S.F	Voltage	In	Imax	Istart	PF%		Efficiency%		Nn	Thrust	Cable		N.W	G.W
	HP	KW		V	A	A	A	allowable Load	overload Factor	allowable Load	overload Factor	RPM	N	M	AWG	kg	kg
ECT-4CF3536D	1.5	1.1	1.3	220	8.8	11.3	41.4	0.87	0.91	65.1	62.8	3450	3000N	1.2	14	12.95	13.34
				230	8.6	10.5	44.0	0.84	0.89								
ECT-4CF3546D	2.0	1.5	1.25	220	11.4	13.9	49.4	0.89	0.95	66.2	66.8	3450	3000N	1.2	14	14.50	15.05
				230	11.4	13.5	52.6	0.86	0.89								
ECT-4CF4556D	3.0	2.2	1.15	220	14.4	16.6	70.5	0.98	0.98	70.6	70.7	3450	4000N	2.5	14	18.03	18.79
				230	13.9	15.8	74.0	0.97	0.97								
ECT-4CF6566D	5.0	3.7	1.15	220	24.2	28.1	101.1	0.99	0.99	69.9	69.3	3450	6000N	2.5	14	28.75	29.73
				230	22.9	26.2	106.7	0.99	0.99								

* To be used with Double Capacitor (Run & Start) type control box.

* Lightning arrester is available in option.

ECT-4CF



ECT PUMP

Control Box

Single Phase 60HZ

EU standard

MODEL	TYPE	HZ	POWER	VOLTAGE	REMARK	START CAPACITOR MFD	RUN CAPACITOR UF	RELAY
ECT-SBC60SA	START CAPACITOR (SMALL BOX)	60	0.5HP	110~115V	START CAPACITOR * 1 + RELAY * 1	250-300MFD 250V	-	P.U: 63~72 VAC D.O: 20~40 VAC FLA :16A 277V RES:35A 277V
ECT-SBC50SA	START CAPACITOR (SMALL BOX)	60	0.5HP	220~230V	START CAPACITOR * 1 + RELAY * 1	59 - 71MFD 250V	-	P.U:195~224 VAC D.O: 60~121 VAC FLA:16A 277V RES:35A 277V
ECT-SBC51SA			0.75HP			86-103MFD 250V	-	
ECT-SBC52SA			1.0HP			105-126MFD 250V	-	
ECT-BBC53DA	DOUBLE CAPACITOR (BIG BOX)	60	1.5HP	220~230V	START CAPACITOR * 1 RUN CAPACITOR * 1 RELAY * 1 OVERLOAD PROTECTOR (1.5 HP * 1 , 2 - 5 HP * 2)	105-126MFD 250V	16UF 400V	P.U:195~224 VAC D.O: 60~121 VAC FLA:16A 277V RES:35A 277V
ECT-BBC54DA			2.0HP			105-126MFD 250V	20UF 400V	
ECT-BBC55DA			3.0HP			208-250MFD 250V	45UF 400V	
ECT-BBC56DA			5.0HP			270-324MFD 250V	80UF 400V	

Dimension

Type	Model	Carton box size			Bottom knockouts		Side knockouts	
		L	W	H	Quantity	Diameter	Quantity	Diameter
ECT-CSIR (ECT-CS)	SBC60SA	25cm (9.9")	14cm (5.5")	9cm (3.6")	2	Ø21.9mm (Ø0.86")	2	Ø21.9mm (Ø0.86")
	SBC50SA							
	SBC51SA							
	SBC52SA							
ECT-CSCR (ECT-CSR)	BBC53DA	29cm (11.5")	21.5cm (8.5")	16.5cm (6.5")	2	Ø33mm (Ø1.3")	-	-
	BBC54DA							
	BBC55DA							
	BBC56DA							

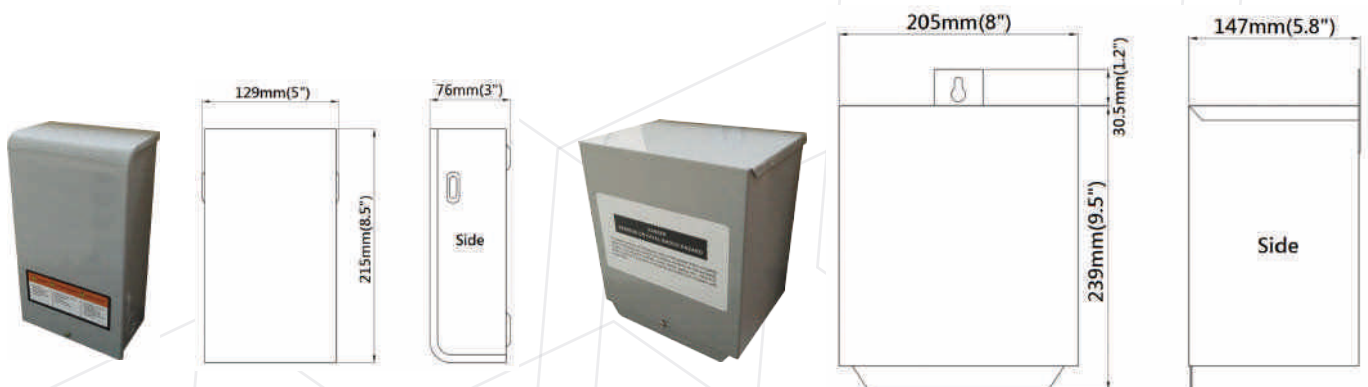



Technical Data

Three Phase 60HZ 220-230V

Motor	P2		S.F	Voltage V	In A	Imax A	Istart A	PF%		Efficiency%		Nn RPM	Thrust N	Cable		N.W kg	G.W kg
	HP	KW						allowable Load	overload Factor	allowable Load	overload Factor			M	AWG		
ECT-4CF2906	0.5	0.37	1.6	220	2.2	2.8	14.2	0.62	0.75	67.7	72.6	3450	2000N	1.2	14	8.79	9.18
				230	2.4	2.8	15.0	0.57	0.71								
ECT-4CF2916	0.75	0.55	1.5	220	3.6	4.1	23.6	0.59	0.71	67.9	70.9	3450	2000N	1.2	14	9.85	10.24
				230	4.0	4.3	25.2	0.53	0.65								
ECT-4CF3926	1.0	0.75	1.4	220	3.6	4.5	18.8	0.75	0.82	72.5	74.1	3450	3000N	1.2	14	10.85	11.24
				230	3.6	4.4	20.0	0.71	0.80								
ECT-4CF3936	1.5	1.1	1.3	220	4.8	5.9	33.2	0.77	0.82	76.7	75.7	3450	3000N	1.2	14	10.89	11.28
				230	4.8	6.4	34.8	0.73	0.82								
ECT-4CF3946	2.0	1.5	1.25	220	6.5	7.7	35.5	0.79	0.84	76.3	76.2	3450	3000N	1.2	14	13.21	13.6
				230	6.5	7.5	34.1	0.76	0.81								
ECT-4CF4956	3.0	2.2	1.15	220	9.6	10.6	54.3	0.78	0.81	77.1	77.2	3450	4000N	2.5	14	15.07	15.62
				230	9.8	10.6	56.0	0.73	0.77								
ECT-4CF6966	4.0	3.0	1.15	220	13.2	14.6	98.9	0.77	0.80	77.2	77.0	3450	6000N	2.5	14	21.74	22.55
				230	13.4	14.6	103.9	0.73	0.77								
ECT-4CF6976	5.0	3.7	1.15	220	15.9	17.7	84.3	0.81	0.84	75.3	74.9	3450	6000N	2.5	14	21.83	22.67
				230	15.7	17.3	88.4	0.78	0.81								
ECT-4CF6996	7.5	5.5	1.15	220	24.1	26.6	123.4	0.77	0.80	77.4	77.2	3450	6000N	2.5	14	29.08	30.06
				230	24.7	26.9	126.2	0.73	0.77								

Three Phase 60HZ 380-400V

Motor	P2		S.F	Voltage V	In A	Imax A	Istart A	PF%		Efficiency%		Nn RPM	Thrust N	Cable		N.W kg	G.W kg
	HP	KW						allowable Load	overload Factor	allowable Load	overload Factor			M	AWG		
ECT-4CF2806	0.5	0.37	1.6	380	1.3	1.6	7.1	0.62	0.75	67.7	72.6	3450	2000N	1.2	14	9.24	9.63
				400	1.4	1.6	7.5	0.57	0.71								
ECT-4CF2816	0.75	0.55	1.5	380	2.1	2.4	11.8	0.59	0.71	67.9	72.5	3450	2000N	1.2	14	10.35	10.74
				400	2.3	2.5	12.6	0.53	0.65								
ECT-4CF3826	1.0	0.75	1.4	380	2.1	2.8	13.1	0.74	0.82	74.5	75.2	3450	3000N	1.2	14	11.46	11.85
				400	2.1	2.7	13.9	0.70	0.79								
ECT-4CF3836	1.5	1.1	1.3	380	2.8	3.4	16.6	0.77	0.82	76.7	75.7	3450	3000N	1.2	14	11.43	11.82
				400	2.8	3.8	17.4	0.73	0.82								
ECT-4CF3846	2.0	1.5	1.25	380	3.8	4.5	20.5	0.80	0.84	75.9	75.4	3450	3000N	1.2	14	13.73	14.12
				400	3.8	4.4	19.7	0.76	0.81								
ECT-4CF4856	3.0	2.2	1.15	380	5.6	6.2	27.1	0.77	0.80	77.3	77.4	3450	4000N	2.5	14	15.43	15.98
				400	5.7	6.2	28.0	0.72	0.76								
ECT-4CF6866	4.0	3.0	1.15	380	7.6	8.4	57.1	0.77	0.80	77.2	77.0	3450	6000N	2.5	14	22.35	23.16
				400	7.7	8.4	60.0	0.73	0.77								
ECT-4CF6876	5.0	3.7	1.15	380	9.5	10.6	26.3	0.76	0.79	77.1	76.8	3450	6000N	2.5	14	22.49	23.33
				400	9.7	10.6	27.5	0.72	0.75								
ECT-4CF6896	7.5	5.5	1.15	380	14.0	15.5	61.7	0.76	0.80	77.3	77.2	3450	6000N	2.5	14	29.62	30.6
				400	14.4	15.6	63.1	0.71	0.75								

Three Phase 60HZ 460V

Motor	P2		S.F	Voltage V	In A	Imax A	Istart A	PF%		Efficiency%		Nn RPM	Thrust N	Cable		N.W kg	G.W kg
	HP	KW						allowable Load	overload Factor	allowable Load	overload Factor			M	AWG		
ECT-4CF2306	0.5	0.37	1.6	460	0.9	1.3	4.5	0.72	0.82	67.9	70.5	3450	2000N	1.2	14	8.62	9.01
ECT-4CF2316	0.75	0.55	1.5	460	1.9	2.2	10.6	0.54	0.67	65.8	71.2	3450	2000N	1.2	14	9.88	10.27
ECT-4CF3326	1.0	0.75	1.4	460	3.0	3.2	19.1	0.48	0.58	65.2	70.5	3450	3000N	1.2	14	11.03	11.42
ECT-4CF3336	1.5	1.1	1.3	460	2.5	3.0	15.5	0.74	0.80	72.7	72.0	3450	3000N	1.2	14	10.98	11.37
ECT-4CF3346	2.0	1.5	1.25	460	3.7	4.1	23.1	0.68	0.74	75.4	76.2	3450	3000N	1.2	14	13.32	13.71
ECT-4CF4356	3.0	2.2	1.15	460	4.9	5.4	28.8	0.74	0.77	75.7	76.1	3450	4000N	2.5	14	14.92	15.47
ECT-4CF6366	4.0	3.0	1.15	460	6.6	7.2	52.3	0.75	0.79	75.8	76.1	3450	6000N	2.5	14	22.01	22.82
ECT-4CF6376	5.0	3.7	1.15	460	8.7	9.5	68.4	0.68	0.72	77.4	77.9	3450	6000N	2.5	14	24.99	25.88
ECT-4CF6396	7.5	5.5	1.15	460	10.9	12.1	78.3	0.79	0.83	79.1	78.7	3450	6000N	2.5	14	29.14	30.12



Technical Data

DOL (One Cable Only)

Three Phase 50HZ 220-240V

Motor	P2		Voltage V	In A	Istart A	PF% COSφ	Efficiency %	Nn RPM	Thrust N	Cable		N.W kg	G.W kg
	HP	KW								M	mm ²		
ECT-6CF7205D	5.5	4.0	220	16.5	59.1	0.86	73.7	2850	15500N	4	4	39.15	44.55
			230	17.0	62.0	0.81							
			240	16.6	64.4	0.78							
ECT-6CF7215D	7.5	5.5	220	21.8	103.1	0.84	78.4	2850	15500N	4	4	43.75	49.50
			230	21.8	108.6	0.80							
			240	22.2	110.5	0.75							
ECT-6CF7225D	10	7.5	220	28.9	117.1	0.86	79.1	2850	15500N	4	4	47.13	53.15
			230	28.6	125.4	0.82							
			240	28.9	130.9	0.78							
ECT-6CF7245D	15	11.0	220	43.6	105.1	0.86	77.0	2850	15500N	4	4	53.35	59.49
			230	42.8	112.9	0.82							
			240	42.8	118.5	0.78							
ECT-6CF7265D	20	15.0	220	57.5	246.5	0.86	79.7	2850	15500N	4	6	58.78	65.59
			230	57.7	262.9	0.81							
			240	59.2	276.4	0.76							
ECT-6CF7275D	25	18.5	220	70.3	234.7	0.85	80.6	2850	15500N	4	8.4	65.18	72.95
			230	66.7	248.5	0.83							
			240	65.3	258.8	0.81							
ECT-6CF7285D	30	22.0	220	85.2	241.4	0.89	76.3	2850	15500N	4	8.4	70.90	78.17
			230	78.1	254.6	0.87							
			240	75.3	271.8	0.86							

Three Phase 50HZ 380-415V

Motor	P2		Voltage V	In A	Istart A	PF% COSφ	Efficiency %	Nn RPM	Thrust N	Cable		N.W kg	G.W kg
	HP	KW								M	mm ²		
ECT-6CF7405D	5.5	4.0	380	9.5	34.1	0.86	73.7	2850	15500N	4	4	39.15	44.55
			400	9.8	35.8	0.81							
			415	9.6	37.2	0.78							
ECT-6CF7415D	7.5	5.5	380	12.6	59.5	0.84	78.4	2850	15500N	4	4	43.75	49.50
			400	12.6	62.7	0.80							
			415	12.8	63.8	0.75							
ECT-6CF7425D	10	7.5	380	16.7	67.6	0.86	79.1	2850	15500N	4	4	47.13	53.15
			400	16.5	72.4	0.82							
			415	16.7	75.6	0.78							
ECT-6CF7445D	15	11.0	380	25.2	60.7	0.86	77.0	2850	15500N	4	4	53.35	59.49
			400	24.7	65.2	0.82							
			415	24.7	68.4	0.78							
ECT-6CF7465D	20	15.0	380	33.2	142.3	0.86	79.7	2850	15500N	4	4	58.78	65.32
			400	33.3	151.8	0.81							
			415	34.2	159.6	0.76							
ECT-6CF7475D	25	18.5	380	40.6	135.5	0.85	80.6	2850	15500N	4	4	65.18	72.24
			400	39.2	143.5	0.83							
			415	39.8	149.4	0.79							
ECT-6CF7485D	30	22.0	380	49.2	139.4	0.89	76.3	2850	15500N	4	6	70.90	78.44
			400	45.1	147.0	0.87							
			415	43.5	156.9	0.86							
ECT-6CF8505D	40	30.0	380	63.6	288.2	0.83	81.6	2850	27500N	4	8.4	82.58	92.47
			400	64.0	305.4	0.87							
			415	64.4	318.0	0.79							
ECT-6CF8515D	50	37.0	380	78.1	358.0	0.88	81.1	2850	27500N	4	8.4	116.87	127.20
			400	76.4	382.0	0.85							
			415	76.8	399.0	0.81							



Technical Data

Y-Δ (Two Cable)

Three Phase 50HZ 220-240V

Motor	P2		Voltage	In	Istart	PF%	Efficiency	Nn	Thrust	Cable		N.W	G.W
	HP	KW	V	A	A	COSφ				%	RPM		
ECT-6CF7205W	5.5	4.0	220	16.5	59.1	0.86	73.7	2850	15500N	4	4	39.21	45.78
			230	17.0	62.0	0.81							
			240	16.6	64.4	0.78							
ECT-6CF7215W	7.5	5.5	220	21.8	103.1	0.84	78.4	2850	15500N	4	4	43.81	50.73
			230	21.8	108.6	0.80							
			240	22.2	110.5	0.75							
ECT-6CF7225W	10	7.5	220	28.9	117.1	0.86	79.1	2850	15500N	4	4	47.19	54.38
			230	28.6	125.4	0.82							
			240	28.9	130.9	0.78							
ECT-6CF7245W	15	11.0	220	43.6	105.1	0.86	77.0	2850	15500N	4	4	53.41	60.72
			230	42.8	112.9	0.82							
			240	42.8	118.5	0.78							
ECT-6CF7265W	20	15.0	220	57.5	246.5	0.86	79.7	2850	15500N	4	4	58.84	66.55
			230	57.7	262.9	0.81							
			240	59.2	276.4	0.76							
ECT-6CF7275W	25	18.5	220	70.3	234.7	0.85	80.6	2850	15500N	4	4	65.24	73.47
			230	66.7	248.5	0.83							
			240	65.3	258.8	0.81							
ECT-6CF7285W	30	22.0	220	85.2	241.4	0.89	76.3	2850	15500N	4	4	70.96	79.40
			230	78.1	254.6	0.87							
			240	75.3	271.8	0.86							

Three Phase 50HZ 380-415V

Motor	P2		Voltage	In	Istart	PF%	Efficiency	Nn	Thrust	Cable		N.W	G.W
	HP	KW	V	A	A	COSφ				%	RPM		
ECT-6CF7405W	5.5	4.0	380	9.5	34.1	0.86	73.7	2850	15500N	4	4	39.21	45.78
			400	9.8	35.8	0.81							
			415	9.6	37.2	0.78							
ECT-6CF7415W	7.5	5.5	380	12.6	59.5	0.84	78.4	2850	15500N	4	4	43.81	50.73
			400	12.6	62.7	0.80							
			415	12.8	63.8	0.75							
ECT-6CF7425W	10	7.5	380	16.7	67.6	0.86	79.1	2850	15500N	4	4	47.19	54.38
			400	16.5	72.4	0.82							
			415	16.7	75.6	0.78							
ECT-6CF7445W	15	11.0	380	25.2	60.7	0.86	77.0	2850	15500N	4	4	53.41	60.72
			400	24.7	65.2	0.82							
			415	24.7	68.4	0.78							
ECT-6CF7465W	20	15.0	380	33.2	142.3	0.86	79.7	2850	15500N	4	4	58.84	66.55
			400	33.3	151.8	0.81							
			415	34.2	159.6	0.76							
ECT-6CF7475W	25	18.5	380	40.6	135.5	0.85	80.6	2850	15500N	4	4	65.24	73.47
			400	39.2	143.5	0.83							
			415	39.8	149.4	0.79							
ECT-6CF7485W	30	22.0	380	49.2	139.4	0.89	76.3	2850	15500N	4	4	70.96	79.40
			400	45.1	147.0	0.87							
			415	43.5	156.9	0.86							
ECT-6CF8505W	40	30.0	380	65.0	214.3	0.86	80.7	2850	27500N	4	4	82.64	92.99
			400	62.6	227.1	0.83							
			415	62.0	219.4	0.81							
ECT-6CF8515W	50	37.0	380	75.8	250.0	0.90	81.8	2850	27500N	4	4	116.93	127.72
			400	72.9	264.0	0.88							
			415	72.4	275.0	0.85							



Technical Data

DOL (One Cable Only)

Three Phase 60HZ 220-230V

Motor	P2		S.F	Voltage	In	Imax	Istart	PF%		Efficiency%		Nn	Thrust	Cable		N.W	G.W
	HP	KW		V	A	A	A	allowable Load	overload Factor	allowable Load	overload Factor	RPM	N	M	AWG	kg	kg
ECT-6CF7106D	5	3.7	1.15	220	15.4	17.3	71.8	0.82	0.84	76.2	76.3	3450	15500N	4	10		46.35
				230	15.6	17.2	76.2	0.78	0.81								
ECT-6CF7116D	7.5	5.5	1.15	220	21.7	24.2	130.2	0.83	0.85	79.9	80.1	3450	15500N	4	10	43.93	49.68
				230	22.1	24.2	139.0	0.78	0.81								
ECT-6CF7126D	10	7.5	1.15	220	28.5	32.4	107.0	0.87	0.88	78.9	78.4	3450	15500N	4	10	47.06	53.08
				230	27.9	31.4	112.0	0.85	0.87								
ECT-6CF7136D	15	11.0	1.15	220	41.8	48.7	148.0	0.87	0.87	79.3	77.7	3450	15500N	4	10	51.26	57.67
				230	40.2	46.1	156.0	0.85	0.86								
ECT-6CF7146D	20	15.0	1.15	220	55.8	65.0	203.0	0.84	0.84	79.1	76.1	3450	15500N	4	8	58.41	65.22
				230	54.0	63.5	213.0	0.86	0.84								
ECT-6CF7156D	25	18.5	1.15	220	70.1	80.8	302.4	0.84	0.85	81.9	80.8	3450	15500N	4	8	64.82	72.59
				230	69.1	77.8	317.1	0.81	0.83								
ECT-6CF7166D	30	22.0	1.15	220	85.5	95.6	429.6	0.82	0.85	81.4	81.2	3450	15500N	4	8	68.48	76.46
				230	88.3	96.9	451.0	0.77	0.81								

Three Phase 60HZ 380V

Motor	P2		S.F	Voltage	In	Imax	Istart	PF%		Efficiency%		Nn	Thrust	Cable		N.W	G.W
	HP	KW		V	A	A	A	allowable Load	overload Factor	allowable Load	overload Factor	RPM	N	M	AWG	kg	kg
ECT-6CF7206D	5	3.7	1.15	380	8.9	10.0	71.8	0.82	0.84	76.2	76.3	3450	15500N	4	10	40.95	46.35
ECT-6CF7216D	7.5	5.5	1.15	380	12.5	14.0	130.2	0.83	0.85	79.9	80.1	3450	15500N	4	10	43.93	49.68
ECT-6CF7226D	10	7.5	1.15	380	16.5	19.1	107.0	0.84	0.90	79.1	77.7	3450	15500N	4	10	47.06	53.08
ECT-6CF7236D	15	11.0	1.15	380	24.1	28.1	148.0	0.87	0.87	79.3	77.7	3450	15500N	4	10	51.26	57.67
ECT-6CF7246D	20	15.0	1.15	380	33.6	39.2	203.0	0.86	0.87	78.1	76.1	3450	15500N	4	10	58.41	64.95
ECT-6CF7256D	25	18.5	1.15	380	40.5	46.7	302.4	0.84	0.85	81.9	80.8	3450	15500N	4	10	64.82	72.15
ECT-6CF7266D	30	22.0	1.15	380	49.3	55.0	429.6	0.81	0.84	82.9	82.8	3450	15500N	4	10	68.48	76.02
ECT-6CF8276D	40	30.0	1.15	380	69.3	76.6	387.0	0.83	0.83	79.2	82.2	3450	27500N	4	8	83.75	93.64
ECT-6CF8286D	50	37.0	1.15	380	78.6	88.0	476.0	0.84	0.87	84.2	84.2	3450	27500N	4	8	117.51	127.84

Three Phase 60HZ 460V

Motor	P2		S.F	Voltage	In	Imax	Istart	PF%		Efficiency%		Nn	Thrust	Cable		N.W	G.W
	HP	KW		V	A	A	A	allowable Load	overload Factor	allowable Load	overload Factor	RPM	N	M	AWG	kg	kg
ECT-6CF7306D	5	3.7	1.15	460	7.9	8.8	37.1	0.77	0.80	75.8	75.9	3450	15500N	4	10	39.54	44.94
ECT-6CF7316D	7.5	5.5	1.15	460	11.0	12.1	64.8	0.78	0.81	80.3	80.5	3450	15500N	4	10	43.97	49.72
ECT-6CF7326D	10	7.5	1.15	460	14.3	15.9	71.6	0.80	0.83	81.4	81.5	3450	15500N	4	10	47.29	53.31
ECT-6CF7336D	15	11.0	1.15	460	21.2	23.9	67.2	0.80	0.82	81.2	80.8	3450	15500N	4	10	53.35	59.49
ECT-6CF7346D	20	15.0	1.15	460	28.6	31.7	152.0	0.80	0.83	82.0	82.1	3450	15500N	4	10	59.05	65.59
ECT-6CF7356D	25	18.5	1.15	460	34.0	38.0	142.3	0.81	0.83	84.0	83.8	3450	15500N	4	10	65.89	72.95
ECT-6CF7366D	30	22.0	1.15	460	37.6	43.0	148.2	0.87	0.88	84.3	83.6	3450	15500N	4	10	70.63	78.17
ECT-6CF8376D	40	30.0	1.15	460	54.7	61.1	307.8	0.82	0.84	83.5	83.4	3450	27500N	4	8	83.53	92.98
ECT-6CF8386D	50	37.0	1.15	460	65.9	73.8	382.3	0.83	0.86	83.9	83.8	3450	27500N	4	8	116.87	127.2



Technical Data

Y-Δ (Two Cable)

Three Phase 60HZ 220-230V

Motor	P2		S.F	Voltage V	In A	Imax A	Istart A	PF%		Efficiency%		Nn RPM	Thrust N	Cable		N.W kg	G.W kg
	HP	KW						allowable Load	overload Factor	allowable Load	overload Factor			M	AWG		
6CF7106W	5	3.7	1.15	220	15.4	17.3	71.8	0.82	0.84	76.2	76.3	3450	15500N	4	10	41.01	47.58
				230	15.6	17.2	76.2	0.78	0.81								
6CF7116W	7.5	5.5	1.15	220	21.7	24.2	130.2	0.83	0.85	79.9	80.1	3450	15500N	4	10	43.99	50.91
				230	22.1	24.2	139.0	0.78	0.81								
6CF7126W	10	7.5	1.15	220	28.5	32.4	107.0	0.87	0.88	78.9	78.4	3450	15500N	4	10	47.12	54.31
				230	27.9	31.4	112.0	0.85	0.87								
6CF7136W	15	11.0	1.15	220	41.8	48.7	148.0	0.87	0.87	79.3	77.7	3450	15500N	4	10	51.32	58.63
				230	40.2	46.1	156.0	0.85	0.86								
6CF7146W	20	15.0	1.15	220	55.8	65.0	203.0	0.84	0.84	79.1	76.1	3450	15500N	4	10	58.47	66.18
				230	54.0	63.5	213.0	0.86	0.84								
6CF7156W	25	18.5	1.15	220	70.1	80.8	302.4	0.84	0.85	81.9	80.8	3450	15500N	4	10	64.88	73.11
				230	69.1	77.8	317.1	0.81	0.83								
6CF7166W	30	22.0	1.15	220	85.5	95.6	429.6	0.82	0.85	81.4	81.2	3450	15500N	4	10	68.54	76.98
				230	88.3	96.9	451.0	0.77	0.81								

Three Phase 60HZ 380V

Motor	P2		S.F	Voltage V	In A	Imax A	Istart A	PF%		Efficiency%		Nn RPM	Thrust N	Cable		N.W kg	G.W kg
	HP	KW						allowable Load	overload Factor	allowable Load	overload Factor			M	AWG		
6CF7206W	5	3.7	1.15	380	8.9	10.0	71.8	0.82	0.84	76.2	76.3	3450	15500N	4	10	41.01	47.58
6CF7216W	7.5	5.5	1.15	380	12.5	14.0	130.2	0.83	0.85	79.9	80.1	3450	15500N	4	10	43.99	50.91
6CF7226W	10	7.5	1.15	380	16.5	19.1	107.0	0.84	0.90	79.1	77.7	3450	15500N	4	10	47.12	54.31
6CF7236W	15	11.0	1.15	380	24.1	28.1	148.0	0.87	0.87	79.3	77.7	3450	15500N	4	10	51.32	58.63
6CF7246W	20	15.0	1.15	380	33.6	39.2	203.0	0.86	0.87	78.1	76.1	3450	15500N	4	10	58.47	66.18
6CF7256W	25	18.5	1.15	380	40.5	46.7	302.4	0.84	0.85	81.9	80.8	3450	15500N	4	10	64.88	73.11
6CF7266W	30	22.0	1.15	380	49.3	55.0	429.6	0.81	0.84	82.9	82.8	3450	15500N	4	10	68.54	76.98
6CF8276W	40	30.0	1.15	380	64.8	75.0	481.0	0.83	0.85	83.0	83.0	3450	27500N	4	10	83.81	94.16
6CF8286W	50	37.0	1.15	380	82.0	93.2	501.0	0.84	0.85	82.0	83.0	3450	27500N	4	8	117.57	128.9